

WINSTAR Display

OLED SPECIFICATION

Model No:

WEG010016J

General Specification

Item	Dimension	Unit
Dot Matrix	100*16 Dots	—
Module dimension	122.0 x 44.0 x 10.0(MAX)	mm
View area	98.00 x 21.00	mm
Active area	95.94 x 17.86	mm
Dot size	0.90 x 1.06	mm
Dot pitch	0.96 x 1.12	mm
Panel Type	OLED , Yellow	
Duty	1/16	
IC	WS0010-TX	
Interface	6800	
Size	3.84 inch	

Contour Drawing & Block Diagram

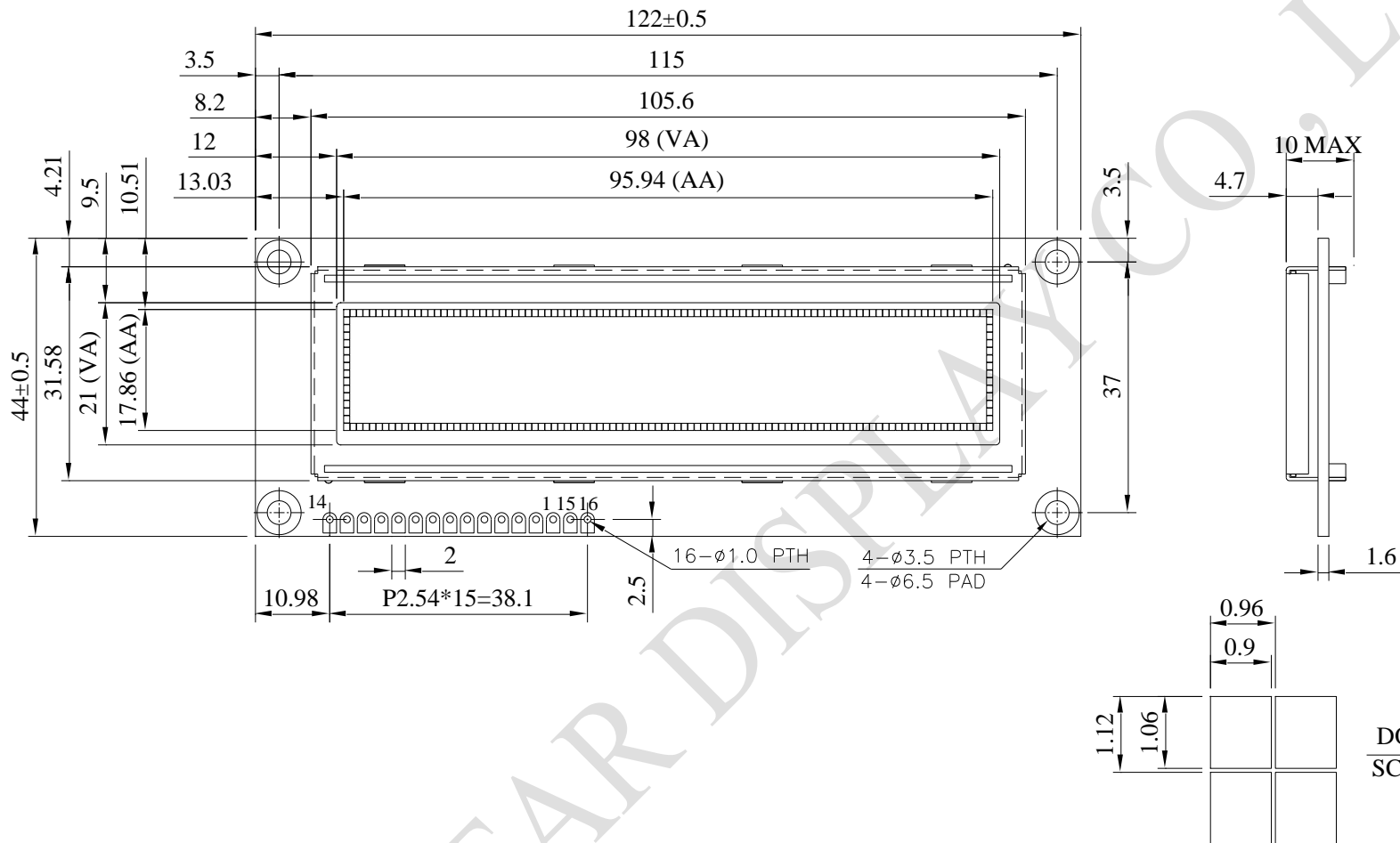

PIN	SYMBOL
1	VSS
2	VDD
3	NC
4	RS
5	R/W
6	E
7	DB0
8	DB1
9	DB2
10	DB3
11	DB4
12	DB5
13	DB6
14	DB7
15	NC
16	NC

The non-specified tolerance of dimension is ± 0.3 mm .

Interface Pin Function

Pin No.	Symbol	Level	Description
1	VSS	0V	Ground
2	VDD	5.0V	Supply Voltage for logic
3	NC	—	No connection
4	RS	H/L	H: DATA, L: Instruction code
5	R/W	H/L	H: Read(Module→MPU) L: Write(MPU→Module)
6	E	H,H→L	Chip enable signal
7	DB0	H/L	Data bit 0
8	DB1	H/L	Data bit 1
9	DB2	H/L	Data bit 2
10	DB3	H/L	Data bit 3
11	DB4	H/L	Data bit 4
12	DB5	H/L	Data bit 5
13	DB6	H/L	Data bit 6
14	DB7	H/L	Data bit 7
15	NC	—	No connection
16	NC	—	No connection

Absolute Maximum Ratings

Item	Symbol	Min	Max	Unit
Operating Temperature	TOP	-40	+80	°C
Storage Temperature	TST	-40	+85	°C
Supply Voltage For Logic	VDD-VSS	-0.3	5.3	V

Electrical Characteristics

DC Electrical Characteristics

Item	Symbol	Condition	Min	Typ	Max	Unit
Supply Voltage For Logic	VDD-VSS	—	4.8	5.0	5.3	V
Input High Volt.	VIH	—	0.8xVDD	—	VDD	V
Input Low Volt.	VIL	—	GND	—	0.2xVDD	V
Output High Volt.	VOH	IOH=-0.5mA	0.8xVDD	—	VDD	V
Output Low Volt.	VOL	IOL=0.5mA	GND	—	0.2xVDD	V
Display 50% Pixel on	IDD	VDD=5V	—	50	75	mA