



## SPECIFICATION

**MODULE NO.:WF52ATLBSDBN0#**

### General Specifications

Item	Dimension	Unit
Size	5.2	inch
Dot Matrix	480 x RGBx128	dots
Module dimension	180.0 x 65.0 x 8.8	mm
Active area	127.152 x 33.9072	mm
Dot pitch	0.0883 x 0.2649	mm
LCD type	TFT, Normally White, Transmissive	
View Direction	6o'clock	
Gray Scale Inversion Direction	12 o'clock	
Backlight Type	LED,Normally White	
Driver IC	SSD1963	
Interface	Digital 8080 family MPU 8bit/16bit	
With /Without TP	Without TP	
Surface	Glare	

\*Color tone slight changed by temperature and driving voltage.

# Absolute Maximum Ratings

Item	Symbol	Min	Typ	Max	Unit
Operating Temperature	TOP	-20	—	+70	°C
Storage Temperature	TST	-30	—	+80	°C

# Electrical Characteristics

Operating conditions: (CON4.Pin1=GND, Pin2=VDD)

Item	Symbol	Condition	Min	Typ	Max	Unit	Remark
Supply Voltage For LCM	VDD	—	3.0	3.1	3.3	V	-
Supply Current For LCM	IDD	—	—	200	—	mA	Note1

# Interface

## 1. LCM PIN Definition (CON4)

Pin	Symbol	Function
1	GND	System round pin of the IC. Connect to system ground.
2	VDD	Power Supply : +3.3V
3	BL_E	Backlight control signal , H: On \ L: Off
4	C/D	Data/Command select
5	WR	Write strobe signal
6	RD	Read strobe signal
7	DB0	Data bus
8	DB1	Data bus
9	DB2	Data bus
10	DB3	Data bus
11	DB4	Data bus
12	DB5	Data bus
13	DB6	Data bus
14	DB7	Data bus
15	DB8	Data bus (When select 8bits mode, this pin is NC)
16	DB9	Data bus (When select 8bits mode, this pin is NC)
17	DB10	Data bus (When select 8bits mode, this pin is NC)
18	DB11	Data bus (When select 8bits mode, this pin is NC)
19	DB12	Data bus (When select 8bits mode, this pin is NC)
20	DB13	Data bus (When select 8bits mode, this pin is NC)
21	DB14	Data bus (When select 8bits mode, this pin is NC)
22	DB15	Data bus (When select 8bits mode, this pin is NC)
23	NC	No connect
24	NC	No connect
25	CS	Chip select
26	RESET	Hardware reset
27	LR	Right /Left selection; Default R/L=High

28	UD	Up/down selection; Default U/D=High
29	NC	No connection
30	NC	No connection
31	NC	No connection
32	NC	No connection
33	VLED-	VLED- for B/L LED inverter (GND)
34	VLED-	VLED- for B/L LED inverter (GND)
35	VLED+	VLED+ for B/L LED inverter (+5V)
36	VLED+	VLED+ for B/L LED inverter (+5V)

## 2. LCM PIN Definition (CON1)

Pin	Symbol	Function
1	FG	Frame Grand
2	GND	System round pin of the IC. Connect to system ground.
3	VDD	Power Supply : +3.3V
4	BLE	Backlight control signal , H: On \ L: Off
5	WR	Write strobe signal
6	RD	Read strobe signal
7	CS	Chip select
8	C/D	Data/Command select
9	NC	No connect
10	RESET	Hardware reset
11	DB0	Data bus
12	DB1	Data bus
13	DB2	Data bus
14	DB3	Data bus
15	DB4	Data bus
16	DB5	Data bus
17	DB6	Data bus
18	DB7	Data bus
19	NC	No connect
20	NC	No connect
21	VLED+	VLED+ for B/L LED inverter (+5V)
22	VLED-	VLED- for B/L LED inverter (GND)
23	NC	No connect
24	NC	No connect
25	NC	No connect
26	GND	Hardware reset

# Contour Drawing

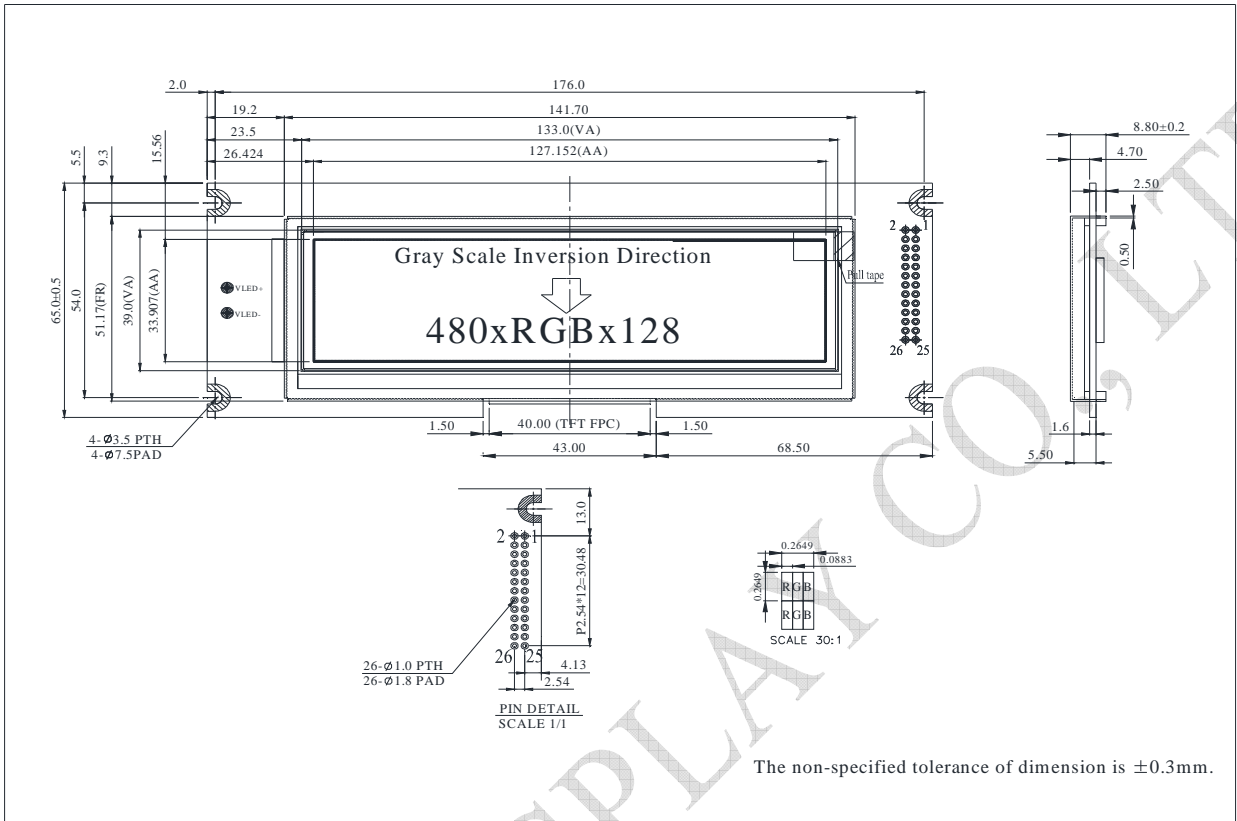

CON1		CON4	
PIN NO.	SYMBOL	PIN NO.	SYMBOL
1	FG	1	GND
2	GND	2	VDD
3	VDD	3	BL_E
4	BLE	4	C/D
5	WR	5	WR
6	RD	6	RD
7	CS	7	DB0
8	C/D	8	DB1
9	NC	9	DB2
10	RESET	10	DB3
11	DB0	11	DB4
12	DB1	12	DB5
13	DB2	13	DB6
14	DB3	14	DB7
15	DB4	15	DB8
16	DB5	16	DB9
17	DB6	17	DB10
18	DB7	18	DB11
19	NC	19	DB12
20	NC	20	DB13
21	VLED+	21	DB14
22	VLED-	22	DB15
23	NC	23	NC
24	NC	24	NC
25	NC	25	CS
26	GND	26	RESET
		27	LR
		28	UD
		29	NC
		30	NC
		31	NC
		32	NC
		33	VLED-
		34	VLED-
		35	VLED+
		36	VLED+

