

WINSTAR Display

OLED SPECIFICATION

Model No:

WEP012864U

General Specification

Item	Dimension	Unit
Dot Matrix	128 x 64 Dots	—
Module dimension	82.0 × 47.5 × 7 Max.	mm
Active Area	61.41 × 30.69	mm
Pixel Size	0.45 × 0.45	mm
Pixel Pitch	0.48 × 0.48	mm
Display Mode	Passive Matrix	
Display Color	Monochrome	
Drive Duty	1/64 Duty	
Gray Scale	4 bits	
OLED IC	SSD1357	
OLED Interface	8-bits 6800 and 8080 parallel, 4-Wire SPI, I2C	
Size	2.7 inch	

Contour Drawing & Block Diagram

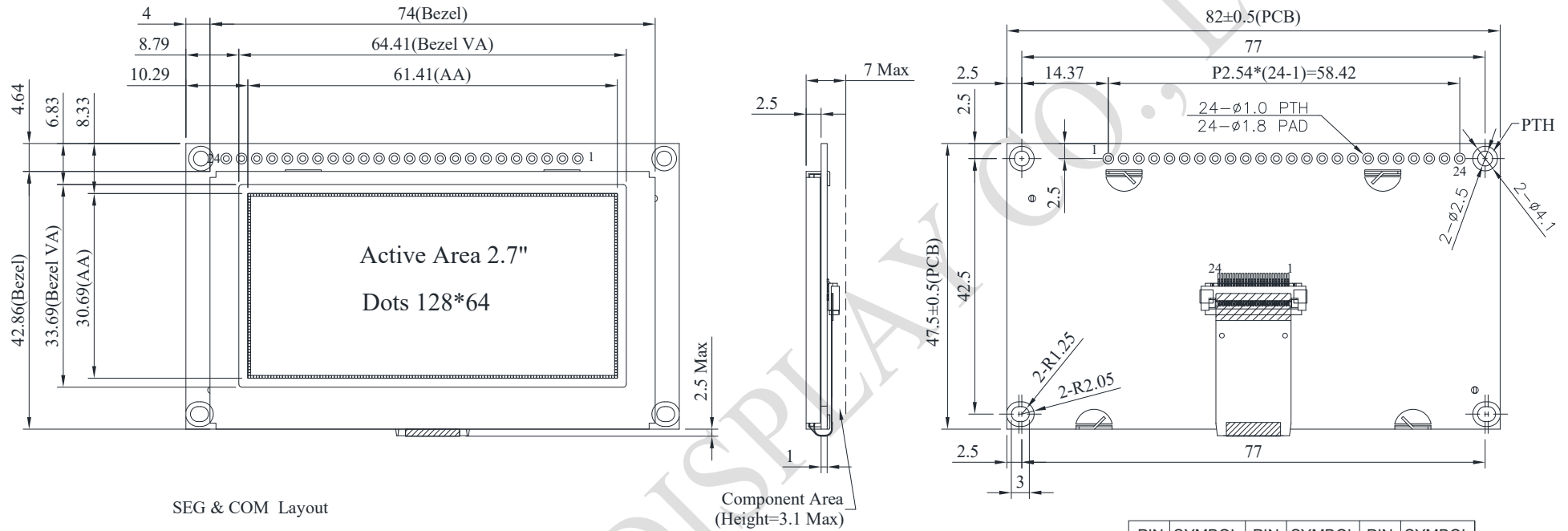

SEG & COM Layout

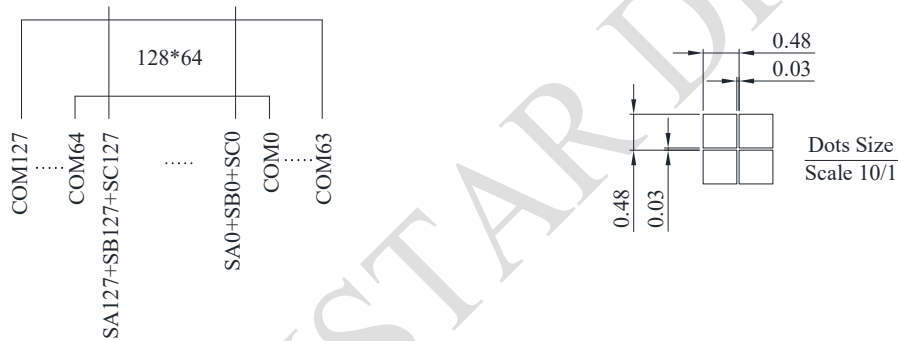

PIN	SYMBOL	PIN	SYMBOL	PIN	SYMBOL
1	VSS	9	DB2	17	CS#
2	VDD	10	DB3	18	NC
3	NC	11	DB4	19	BS2
4	D/C#	12	DB5	20	BS1
5	R/W#(WR#)	13	DB6	21	NC
6	E(/RD#)	14	DB7	22	NC
7	DB0	15	NC	23	NC
8	DB1	16	RES#	24	NC

The non-specified tolerance of dimension is ± 0.3 mm .

Interface Pin Function

No.	Symbol	Function
1	VSS	This is a ground pin.
2	VDD	Power supply pin for core logic operation
3	NC	Reserved Pin The N.C. pin between function pins is reserved for compatible and flexible design.
4	D/C#	This pin is Data/Command control pin connecting to the MCU. When the pin is pulled HIGH, the data at D[7:0] will be interpreted as data. When the pin is pulled LOW, the data at D[7:0] will be transferred to a command register. In I2C mode, this pin acts as SA0 for slave address selection.
5	R/W# (WR#)	This pin is read / write control input pin connecting to the MCU interface. When 6800 interface mode is selected, this pin will be used as Read/Write (R/W#) selection input. Read mode will be carried out when this pin is pulled HIGH and write mode when LOW. When 8080 interface mode is selected, this pin will be the Write (WR#) input. Data write operation is initiated when this pin is pulled LOW and the chip is selected. When serial or I2C interface is selected, this pin must be connected to VSS.
6	E/RD#	This pin is MCU interface input. When 6800 interface mode is selected, this pin will be used as the Enable (E) signal. Read/write operation is initiated when this pin is pulled HIGH and the chip is selected. When 8080 interface mode is selected, this pin receives the Read (RD#) signal. Read operation is initiated when this pin is pulled LOW and the chip is selected. When serial or I2C interface is selected, this pin must be connected to VSS.
7	DB0	These pins are bi-directional data bus connecting to the MCU data bus. Unused pins are recommended to tie LOW. When serial interface mode is selected, D0 will be the serial clock input: SCLK; D1 will be the serial data input: SDIN. When I2C mode is selected, D2, D1 should be tied together and serve as SDAout, SDAin in application and D0 is the serial clock input, SCL.
8	DB1	
9	DB2	
10	DB3	
11	DB4	
12	DB5	
13	DB6	
14	DB7	
15	NC	No connection.
16	RES#	This pin is reset signal input. When the pin is pulled LOW, initialization of the chip is executed. Keep this pin pull HIGH during normal operation.
17	CS#	Chip Select This pin is the chip select input. The chip is enabled for MCU communication only when CS# is pulled low.

18	NC	No connection.															
19	BS2	Communicating Protocol Select.															
20	BS1	These pins are MCU interface selection input. See the following table:															
		<table border="1"> <thead> <tr> <th></th> <th>BS1</th> <th>BS2</th> </tr> </thead> <tbody> <tr> <td>I2C</td> <td>1</td> <td>0</td> </tr> <tr> <td>4-wire Serial</td> <td>0</td> <td>0</td> </tr> <tr> <td>8-bit 8080 Parallel</td> <td>1</td> <td>1</td> </tr> <tr> <td>8-bit 6800 Parallel</td> <td>0</td> <td>1</td> </tr> </tbody> </table>		BS1	BS2	I2C	1	0	4-wire Serial	0	0	8-bit 8080 Parallel	1	1	8-bit 6800 Parallel	0	1
			BS1	BS2													
		I2C	1	0													
		4-wire Serial	0	0													
8-bit 8080 Parallel	1	1															
8-bit 6800 Parallel	0	1															
21	NC	No connection.															
22	NC	No connection.															
23	NC	No connection.															
24	NC	No connection.															

Absolute Maximum Ratings

Parameter	Symbol	Min	Max	Unit
Supply Voltage for Logic	VDD	-0.3	4.0	V
Operating Temperature	TOP	-40	+80	°C
Storage Temperature	TSTG	-40	+85	°C

Electrical Characteristics

DC Electrical Characteristics

Item	Symbol	Condition	Min	Typ	Max	Unit
Supply Voltage for Logic	VDD	—	2.8	3.0	3.3	V
High Level Input	VIH	—	0.8×VDD	—	—	V
Low Level Input	VIL	—	—	—	0.2×VDD	V
High Level Output	VOH	—	0.9×VDD	—	—	V
Low Level Output	VOL	—	—	—	0.1×VDD	V
Display 50% Pixel on	IDD	VDD =3V	—	120	180	mA