

# S6B0108

## 64CH SEGMENT DRIVER FOR DOT MATRIX LCD

July. 2001

Ver. 0.0

Contents in this document are subject to change without notice. No part of this document may be reproduced or transmitted in any form or by any means, electronic or mechanical, for any purpose, without the express written permission of LCD Driver IC Team.

### **Precautions for Light**

Light has characteristics to move electrons in the integrated circuitry of semiconductors, therefore may change the characteristics of semiconductor devices when irradiated with light. Consequently, the users of the packages which may expose chips to external light such as COB, COG, TCP and COF must consider effective methods to block out light from reaching the IC on all parts of the surface area, the top, bottom and the sides of the chip. Follow the precautions below when using the products.

1. Consider and verify the protection of penetrating light to the IC at substrate (board or glass) or product design stage.
2. Always test and inspect products under the environment with no penetration of light.

<b>S6B0755 Specification Revision History</b>		
<b>Version</b>	<b>Content</b>	<b>Date</b>
0.0	Original	July.2001

# CONTENTS

<b>INTRODUCTION</b> .....	<b>1</b>
<b>BLOCK DIAGRAM</b> .....	<b>2</b>
<b>PIN CONFIGURATION</b> .....	<b>3</b>
100 QFP.....	3
PAD DIAGRAM (CHIP LAYOUT FOR THE 100QFP).....	4
PAD CENTER COORDINATES (100QFP).....	5
100TQFP (S6B2108).....	6
PAD DIAGRAM (CHIP LAYOUT FOR THE 100TQFP).....	7
PAD CENTER COORDINATES (100TQFP- S6B2108).....	8
<b>PIN DESCRIPTION</b> .....	<b>9</b>
<b>MAXIMUM ABSOLUTE LIMIT</b> .....	<b>11</b>
<b>ELECTRICAL CHARACTERISTICS</b> .....	<b>12</b>
DC CHARACTERISTICS .....	12
AC CHARACTERISTICS ( $V_{DD} = +5V \pm 10\%$ , $V_{SS} = 0V$ , $T_a = -30$ to $+85^{\circ}C$ ) .....	13
<b>OPERATING PRINCIPLES AND METHODS</b> .....	<b>17</b>
I/O BUFFER .....	17
RESET.....	18
<b>DISPLAY CONTROL INSTRUCTION</b> .....	<b>21</b>
DISPLAY ON/OFF.....	22
STATUS READ.....	23
<b>APPLICATION CIRCUIT</b> .....	<b>24</b>
1/64 DUTY COMMON DRIVER (S6B0107) INTERFACE CIRCUIT .....	24
TIMING DIAGRAM (1/64 DUTY).....	25
LCD PANEL INTERFACE APPLICATION CIRCUIT .....	26



## INTRODUCTION

The S6B0108 (TQFP type: S6B2108) is a LCD driver LSI with 64 channel output for dot matrix liquid crystal graphic display systems. This device consists of the display RAM, 64 bit data latch, 64 bit drivers and decoder logic. It has the internal display RAM for storing the display data transferred from a 8 bit micro controller and generates the dot matrix liquid crystal driving signals corresponding to stored data. The S6B0108 composed of the liquid crystal display system in combination with the S6B0107 (64 channel common driver -TQFP type: S6B2107).

## FEATURES

- Dot matrix LCD segment driver with 64 channel output
- Input and output signal
  - Input: 8 bit parallel display data control signal from MPU divided bias voltage (V0R, V0L, V2R, V2L, V3R, V3L, V5R, V5L)
  - Output: 64 channel for LCD driving.
- Display data is stored in display data RAM from MPU.
- Interface RAM
  - Capacity: 512 bytes (4096 bits)
  - RAM bit data: RAM bit data = 1: On  
RAM bit data = 0: Off
- Applicable LCD duty: 1/32-1/64
- LCD driving voltage: 8V-17V ( $V_{DD}-V_{EE}$ )
- Power supply voltage: + 5V  $\pm$  10%
- Interface

Drivers		Controller
Common	Segment	
S6B0107	Other S6B0108	MPU

- High voltage CMOS process
- 100QFP/100TQFP or bare chip available.

**BLOCK DIAGRAM**

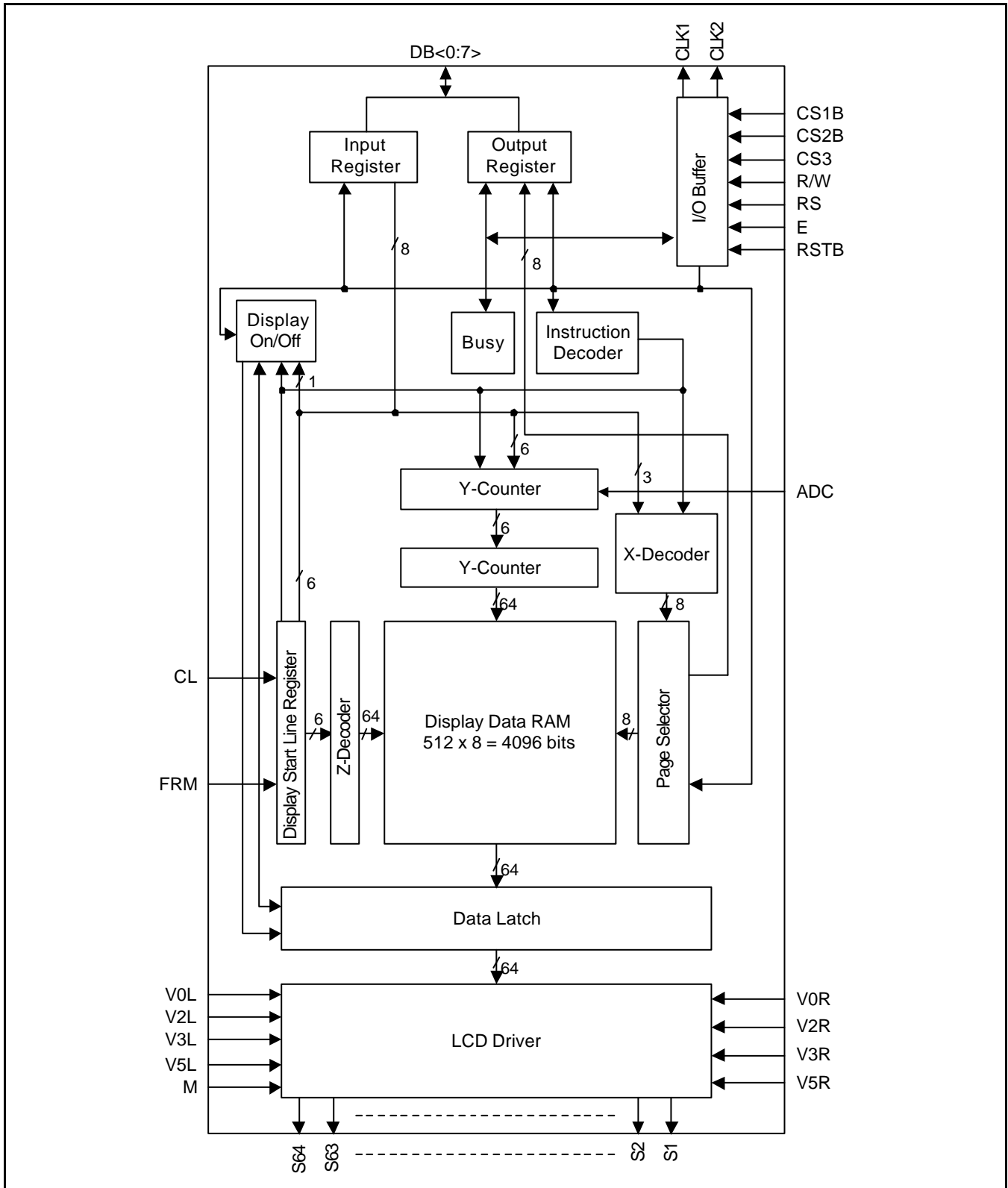

**PIN CONFIGURATION**

100 QFP

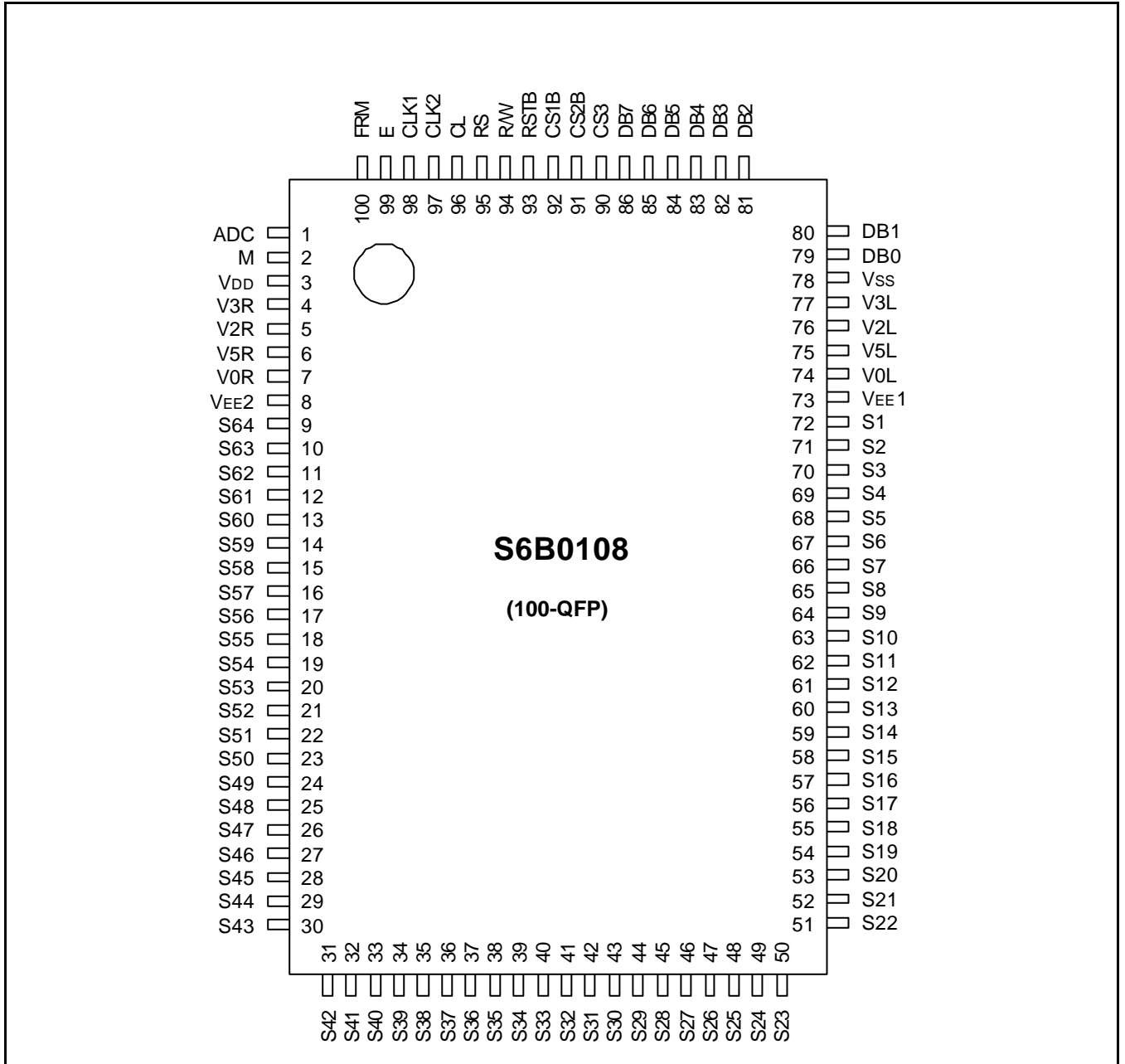

PAD DIAGRAM (CHIP LAYOUT FOR THE 100QFP)

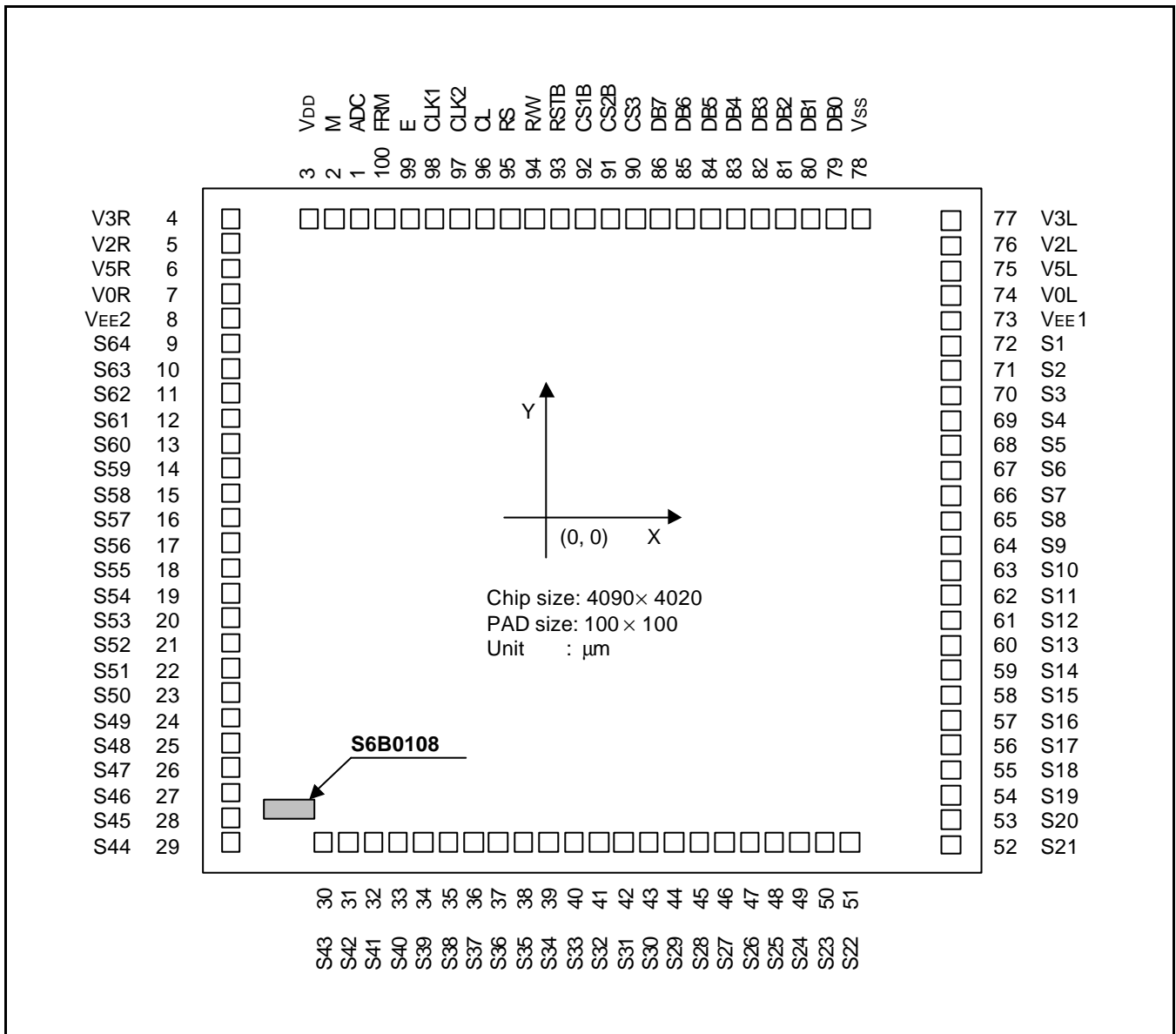

There is mark of S6B0108 on the bottom left in the chip.

## PAD CENTER COORDINATES (100QFP)

PAD Number	PAD Name	Coordinate		PAD Number	PAD Name	Coordinate		PAD Number	PAD Name	Coordinate	
		X	Y			X	Y			X	Y
1	ADC	-1140	1845	35	S38	-687	-1845	69	S4	1882	791
2	M	-1275	1845	36	S37	-562	-1845	70	S3	1882	916
3	V <sub>DD</sub>	-1410	1845	37	S36	-437	-1845	71	S2	1882	1041
4	V3R	-1882	1809	38	S35	-312	-1845	72	S1	1882	1166
5	V2R	-1882	1684	39	S34	-187	-1845	73	V <sub>EE1</sub>	1882	1310
6	V5R	-1882	1559	40	S33	-62	-1845	74	V0L	1882	1435
7	V0R	-1882	1434	41	S32	62	-1845	75	V5L	1882	1559
8	V <sub>EE2</sub>	-1882	1309	42	S31	187	-1845	76	V2L	1882	1684
9	S64	-1882	1165	43	S30	312	-1845	77	V3L	1882	1809
10	S63	-1882	1040	44	S29	437	-1845	78	V <sub>SS</sub>	1412	1845
11	S62	-1882	915	45	S28	562	-1845	79	DB0	1277	1845
12	S61	-1882	790	46	S27	687	-1845	80	DB1	1142	1845
13	S60	-1882	665	47	S26	812	-1845	81	DB2	1007	1845
14	S59	-1882	540	48	S25	937	-1845	82	DB3	882	1845
15	S58	-1882	415	49	S24	1062	-1845	83	DB4	757	1845
16	S57	-1882	290	50	S23	1187	-1845	84	DB5	632	1845
17	S56	-1882	165	51	S22	1487	-1845	85	DB6	507	1845
18	S55	-1882	40	52	S21	1882	-1379	86	DB7	382	1845
19	S54	-1882	-84	53	S20	1882	-1239	90	CS3	245	1845
20	S53	-1882	-209	54	S19	1882	-1099	91	CS2B	120	1845
21	S52	-1882	-334	55	S18	1882	-959	92	CS1B	-5	1845
22	S51	-1882	-459	56	S17	1882	-834	93	RSTB	-130	1845
23	S50	-1882	-584	57	S16	1882	-709	94	R/W	-255	1845
24	S49	-1882	-709	58	S15	1882	-584	95	RS	-380	1845
25	S48	-1882	-834	59	S14	1882	-459	96	CL	-505	1845
26	S47	-1882	-959	60	S13	1882	-334	97	CLK2	-630	1845
27	S46	-1882	-1099	61	S12	1882	-209	98	CLK1	-755	1845
28	S45	-1882	-1239	62	S11	1882	-84	99	E	-880	1845
29	S44	-1882	-1379	63	S10	1882	41	100	FRM	-1005	1845
30	S43	-1487	-1845	64	S9	1882	166				
31	S42	-1187	-1845	65	S8	1882	291				
32	S41	-1062	-1845	66	S7	1882	416				
33	S40	-937	-1845	67	S6	1882	541				
34	S39	-812	-1845	68	S5	1882	666				

100TQFP (S6B2108)

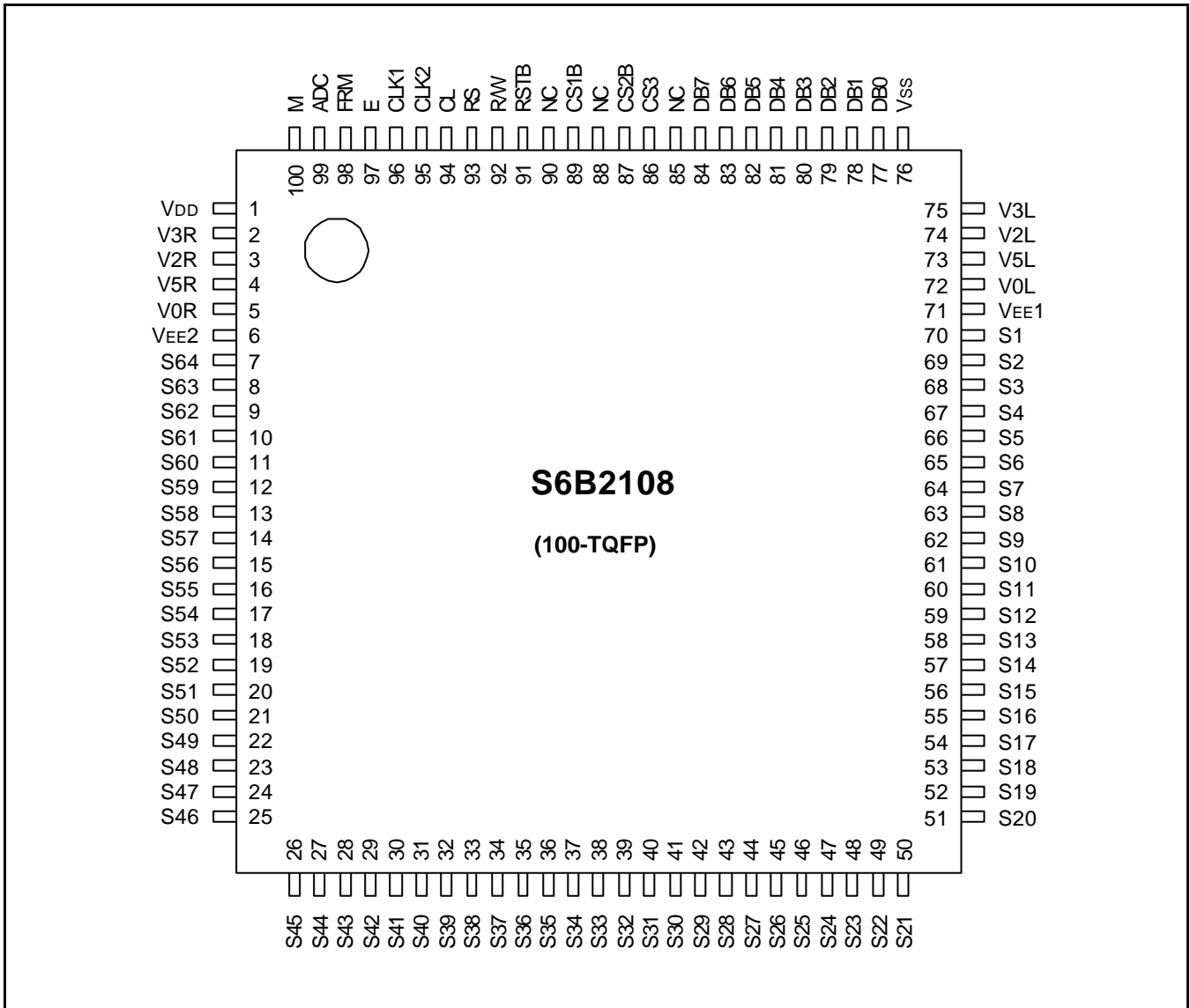

PAD DIAGRAM (CHIP LAYOUT FOR THE 100TQFP)

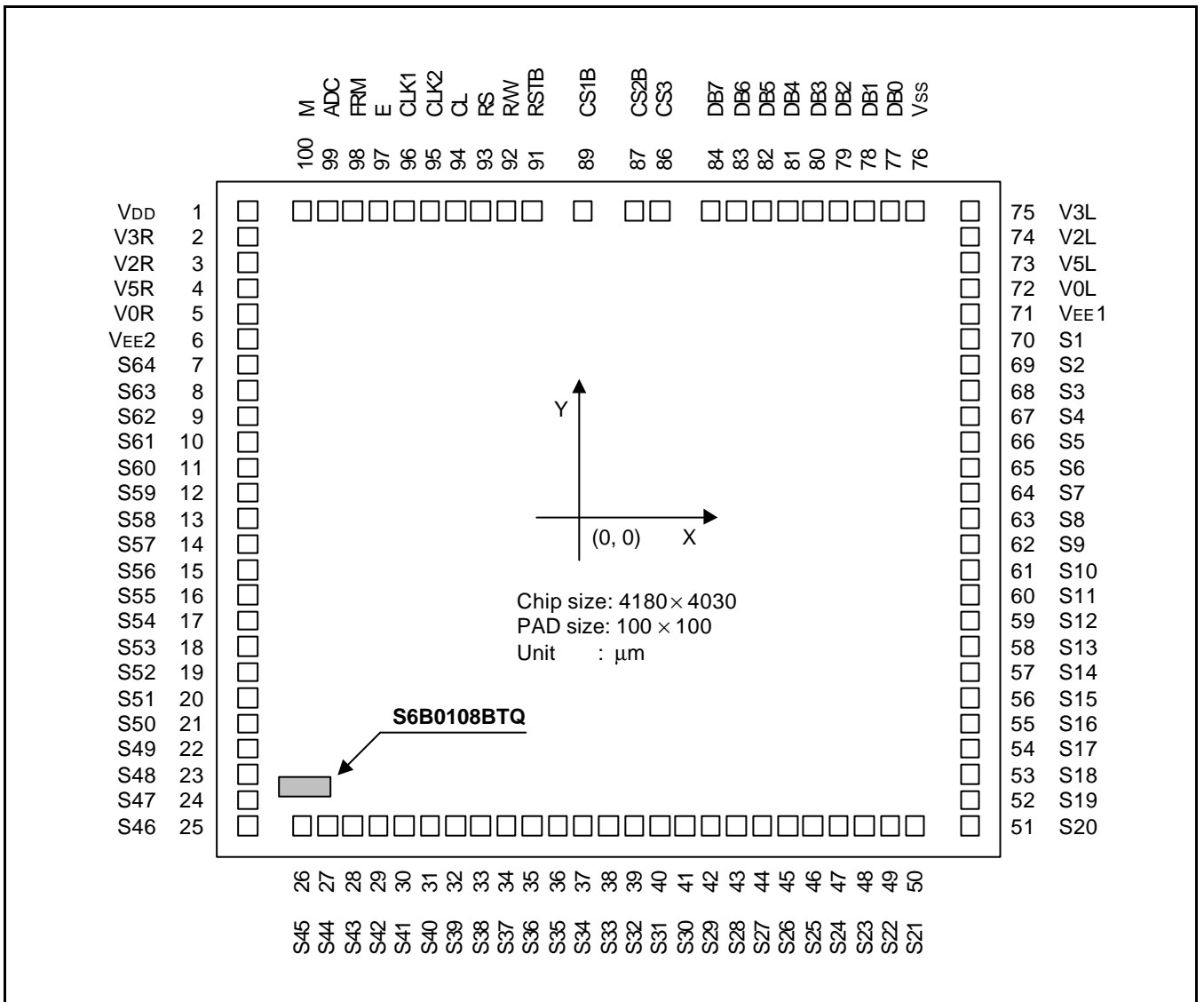

There is mark of S6B2108 on the bottom left in the chip.

## PAD CENTER COORDINATES (100TQFP- S6B2108)

PAD Number	PAD Name	Coordinate		PAD Number	PAD Name	Coordinate		PAD Number	PAD Name	Coordinate	
		X	Y			X	Y			X	Y
1	V <sub>DD</sub>	-1924	1812.5	36	S35	-301.1	-1849	71	V <sub>EE</sub>	1924	1312.5
2	V3	-1924	1687.5	37	S34	-173.9	-1849	72	V0	1924	1437.5
3	V2	-1924	1562.5	38	S33	-46.7	-1849	73	V5	1924	1562.5
4	V5	-1924	1437.5	39	S32	80.5	-1849	74	V2	1924	1687.5
5	V0	-1924	1312.5	40	S31	207.7	-1849	75	V3	1924	1812.5
6	V <sub>EE</sub>	-1924	1187.5	41	S30	334.9	-1849	76	V <sub>SS</sub>	1450.5	1849
7	S64	-1924	1033.2	42	S29	462.1	-1849	77	DB0	1315.5	1849
8	S63	-1924	906	43	S28	589.3	-1849	78	DB1	1180.5	1849
9	S62	-1924	778.8	44	S27	716.5	-1849	79	DB2	1045.5	1849
10	S61	-1924	651.6	45	S26	843.7	-1849	80	DB3	920.5	1849
11	S60	-1924	524.4	46	S25	970.9	-1849	81	DB4	795.5	1849
12	S59	-1924	397.2	47	S24	1098.1	-1849	82	DB5	670.5	1849
13	S58	-1924	270	48	S23	1225.3	-1849	83	DB6	545.5	1849
14	S57	-1924	142.8	49	S22	1352.5	-1849	84	DB7	420.5	1849
15	S56	-1924	15.6	50	S21	1479.7	-1849	85	NC		
16	S55	-1924	-111.6	51	S20	1924	-1245.3	86	CS3	282.8	1849
17	S54	-1924	-238.8	52	S19	1924	-1118.1	87	CS2B	157.8	1849
18	S53	-1924	-366	53	S18	1924	-990.9	88	NC		
19	S52	-1924	-493.2	54	S17	1924	-863.7	89	CS1B	32.8	1849
20	S51	-1924	-620.4	55	S16	1924	-736.5	90	NC		
21	S50	-1924	-747.6	56	S15	1924	-609.3	91	RSTB	-92.2	1849
22	S49	-1924	-874.8	57	S14	1924	-482.1	92	RW	-217.2	1849
23	S48	-1924	-1002	58	S13	1924	-354.9	93	RS	-342.2	1849
24	S47	-1924	-1129.2	59	S12	1924	-227.7	94	CL	467.2	1849
25	S46	-1924	-1256.4	60	S11	1924	-100.5	95	CLK2	-592.2	1849
26	S45	-1573.1	-1849	61	S10	1924	26.7	96	CLK1	-717.2	1849
27	S44	-1445.9	-1849	62	S9	1924	153.9	97	E	-842.2	1849
28	S43	-1318.7	-1849	63	S8	1924	281.1	98	FRW	-967.2	1849
29	S42	-1191.5	-1849	64	S7	1924	408.3	99	ADC	-1177.8	1849
30	S41	-1064.3	-1849	65	S6	1924	535.5	100	M	-1312.8	1849
31	S40	-937.1	-1849	66	S5	1924	662.7				
32	S39	-809.9	-1849	67	S4	1924	789.9				
33	S38	-682.7	-1849	68	S3	1924	917.1				
34	S37	-555.5	-1849	69	S2	1924	1044.3				
35	S36	-428.3	-1849	70	S1	1924	1171.5				

## PIN DESCRIPTION

Table 1. Pin Description

Pin Number QFP(TQFP)	Symbol	Input/Output	Description				
3(1) 78(76) 73(71), 8(6)	$V_{DD}$ $V_{SS}$ $V_{EE1,2}$	Power	For internal logic circuit (+5V $\pm$ 10%) GND (0V) For LCD driver circuit $V_{SS} = 0V$ , $V_{DD} = +5V \pm 10\%$ , $V_{DD} - V_{EE} = 8V - 17V$ $V_{EE1}$ and $V_{EE2}$ is connected by the same voltage.				
74(72), 7(5) 76(74), 5(3) 77(75), 4(2) 75(73), 6(4)	$V_{0L}$ , $V_{0R}$ $V_{2L}$ , $V_{2R}$ $V_{3L}$ , $V_{3R}$ $V_{5L}$ , $V_{5R}$	Power	Bias supply voltage terminals to drive the LCD. <table border="1" style="margin-left: auto; margin-right: auto;"> <thead> <tr> <th>Select Level</th> <th>Non-Select Level</th> </tr> </thead> <tbody> <tr> <td><math>V_{0L(R)}</math>, <math>V_{5L(R)}</math></td> <td><math>V_{2L(R)}</math>, <math>V_{3L(R)}</math></td> </tr> </tbody> </table> $V_{0L}$ and $V_{0R}$ ( $V_{2L}$ & $V_{2R}$ , $V_{3L}$ & $V_{3R}$ , $V_{5L}$ & $V_{5R}$ ) should be connected by the same voltage.	Select Level	Non-Select Level	$V_{0L(R)}$ , $V_{5L(R)}$	$V_{2L(R)}$ , $V_{3L(R)}$
Select Level	Non-Select Level						
$V_{0L(R)}$ , $V_{5L(R)}$	$V_{2L(R)}$ , $V_{3L(R)}$						
92(89) 91(87) 90(86)	CS1B CS2B CS3	Input	Chip selection In order to interface data for input or output, the terminals have to be CS1B = L, CS2B = L, and CS3 = H.				
2(100)	M	Input	Alternating signal input for LCD driving.				
1(99)	ADC	Input	Address control signal to determine the relation between Y address of display RAM and terminals from which the data is output. ADC = H $\rightarrow$ Y0: S1 - Y63: S64 ADC = L $\rightarrow$ Y0: S64 - Y63: S1				
100(98)	FRM	Input	Synchronous control signal. Presets the 6-bit Z counter and synchronizes the common signal with the frame signal when the frame signal becomes high.				
99(97)	E	Input	Enable signal. Write mode (R/W = L) $\rightarrow$ data of DB<0:7> is latched at the falling edge of E. Read mode (R/W = H) $\rightarrow$ DB<0:7> appears the reading data while E is at high level.				
98(96) 97(95)	CLK1 CLK2	Input	2 phase clock signal for internal operation. Used to execute operations for input/output of display RAM data and others.				
96(94)	CL	Input	Display synchronous signal. Display data is latched at rising time of the CL signal and increments the Z-address counter at the CL falling time.				
95(93)	RS	Input	Data or Instruction. RS = H $\rightarrow$ DB<0:7>: Display RAM data RS = L $\rightarrow$ DB<0:7>: Instruction data				

Table 1. Pin Description (Continued)

Pin Number QFP(TQFP)	Symbol	Input/Output	Description													
94(92)	R/W	Input	Read or Write. R/W = H → Data appears at DB<0:7> and can be read by the CPU while E = H, CS1B = L, CS2B = L and CS3 = H . R/W = L → Display data DB<0:7> can be written at falling of E when CS1B = L, CS2B = L and CS3 = H.													
79-86 (77-84)	DB0-DB7	Input/Output	Data bus. There state I/O common terminal.													
72-9 (70-7)	S1-S64	Output	LCD segment driver output. Display RAM data 1: On Display RAM data 0: Off (relation of display RAM data & M) <table border="1" style="margin-left: 20px;"> <thead> <tr> <th>M</th> <th>Data</th> <th>Output Level</th> </tr> </thead> <tbody> <tr> <td rowspan="2">L</td> <td>L</td> <td>V<sub>2</sub></td> </tr> <tr> <td>H</td> <td>V<sub>0</sub></td> </tr> <tr> <td rowspan="2">H</td> <td>L</td> <td>V<sub>3</sub></td> </tr> <tr> <td>H</td> <td>V<sub>5</sub></td> </tr> </tbody> </table>	M	Data	Output Level	L	L	V <sub>2</sub>	H	V <sub>0</sub>	H	L	V <sub>3</sub>	H	V <sub>5</sub>
M	Data	Output Level														
L	L	V <sub>2</sub>														
	H	V <sub>0</sub>														
H	L	V <sub>3</sub>														
	H	V <sub>5</sub>														
93(91)	RSTB	Input	Reset signal. When RSTB=L, - ON/OFF register becomes set by 0. (display off) - Display start line register becomes set by 0 (Z-address 0 set, display from line 0) After releasing reset, this condition can be changed only by instruction.													
87(85), 88(88) 89(90)	NC		No connection. (open)													

**MAXIMUM ABSOLUTE LIMIT**

Characteristic	Symbol	Value	Unit	Note
Operating voltage	$V_{DD}$	-0.3 to +7.0	V	(1)
Supply voltage	$V_{EE}$	$V_{DD}-19.0$ to $V_{DD}+0.3$	V	(4)
Driver supply voltage	$V_B$	-0.3 to $V_{DD}+0.3$	V	(1), (3)
	$V_{LCD}$	$V_{EE}-0.3$ to $V_{DD}+0.3$	V	(2)
Operating temperature	$T_{OPR}$	-30 to +85	°C	
Storage temperature	$T_{STG}$	-55 to +125	°C	

**NOTES:**

1. Based on  $V_{SS} = 0V$ .
2. Applies the same supply voltage to  $V_{EE1}$  and  $V_{EE2}$ .  $V_{LCD} = V_{DD} - V_{EE}$ .
3. Applies to M, FRM, CL, RSTB, ADC, CLK1, CLK2, CS1B, CS2B, CS3, E, R/W, RS and DB0 - DB7.
4. Applies to V0L(R), V2L(R), V3L(R) and V5L(R).  
Voltage level:  $V_{DD} \geq V0L = V0R \geq V2L = V2R \geq V3L = V3R \geq V5L = V5R \geq V_{EE}$ .

## ELECTRICAL CHARACTERISTICS

### DC CHARACTERISTICS

( $V_{DD} = +5V \pm 10\%$ ,  $V_{SS} = 0V$ ,  $V_{DD} - V_{EE} = 8$  to  $17V$ ,  $T_a = -30$  to  $+85^\circ C$ )

Characteristic	Symbol	Condition	Min	Typ	Max	Unit	Note
Input high voltage	$V_{IH1}$	–	$0.7V_{DD}$	–	$V_{DD}$	V	(1)
	$V_{IH2}$	–	2.0	–	$V_{DD}$	V	(2)
Input low voltage	$V_{IL1}$	–	0	–	$0.3V_{DD}$	V	(1)
	$V_{IL2}$	–	0	–	0.8	V	(2)
Output high voltage	$V_{OH}$	$I_{OH} = -200\mu A$	2.4	–	–	V	(3)
Output low voltage	$V_{OL}$	$I_{OL} = 1.6mA$	–	–	0.4	V	(3)
Input leakage current	$I_{LKG}$	$V_{IN} = V_{SS} - V_{DD}$	-1.0	–	1.0	$\mu A$	(4)
Three-state(off) input current	$I_{TSL}$	$V_{IN} = V_{SS} - V_{DD}$	-5.0	–	5.0	$\mu A$	(5)
Driver input leakage current	$I_{DIL}$	$V_{IN} = V_{EE} - V_{DD}$	-2.0	–	2.0	$\mu A$	(6)
Operating current	$I_{DD1}$	During display	–	–	100	$\mu A$	(7)
	$I_{DD2}$	During access Access cycle = 1MHz	–	–	500	$\mu A$	(7)
On resistance	$R_{ON}$	$V_{DD} - V_{EE} = 15V$ $I_{LOAD} = \pm 0.1mA$	–	–	7.5	$K\Omega$	(8)

#### NOTES:

1. CL, FRM, M, RSTB, CLK1, CLK2
2. CS1B, CS2B, CS3, E, R/W, RS, DB0 - DB7
3. DB0 - DB7
4. Except DB0 - DB7
5. DB0 - DB7 at high impedance
6. V0L(R), V2L(R), V3L(R), V5L(R)
7. 1/64 duty, FCLK = 250kHz, frame frequency = 70HZ, output: no load
8.  $V_{DD} - V_{EE} = 15.5V$   
 $V0L(R) > V2L(R) = V_{DD} - 2/7 (V_{DD} - V_{EE}) > V3L(R) = V_{EE} + 2/7 (V_{DD} - V_{EE}) > V5L(R)$

AC CHARACTERISTICS ( $V_{DD} = +5V \pm 10\%$ ,  $V_{SS} = 0V$ ,  $T_a = -30$  to  $+85^\circ C$ )

## Clock Timing

Characteristic	Symbol	Min	Typ	Max	Unit
CLK1, CLK2 cycle time	$t_{CY}$	2.5	–	20	$\mu s$
CLK1 "low" level width	$t_{WL1}$	625	–	–	ns
CLK2 "low" level width	$t_{WL2}$	625	–	–	
CLK1 "high" level width	$t_{WH1}$	1875	–	–	
CLK2 "high" level width	$t_{WH2}$	1875	–	–	
CLK1-CLK2 phase difference	$t_{D12}$	625	–	–	
CLK2-CLK1 phase difference	$t_{D21}$	625	–	–	
CLK1, CLK2 rise time	$t_R$	–	–	150	
CLK1, CLK2 fall time	$t_F$	–	–	150	

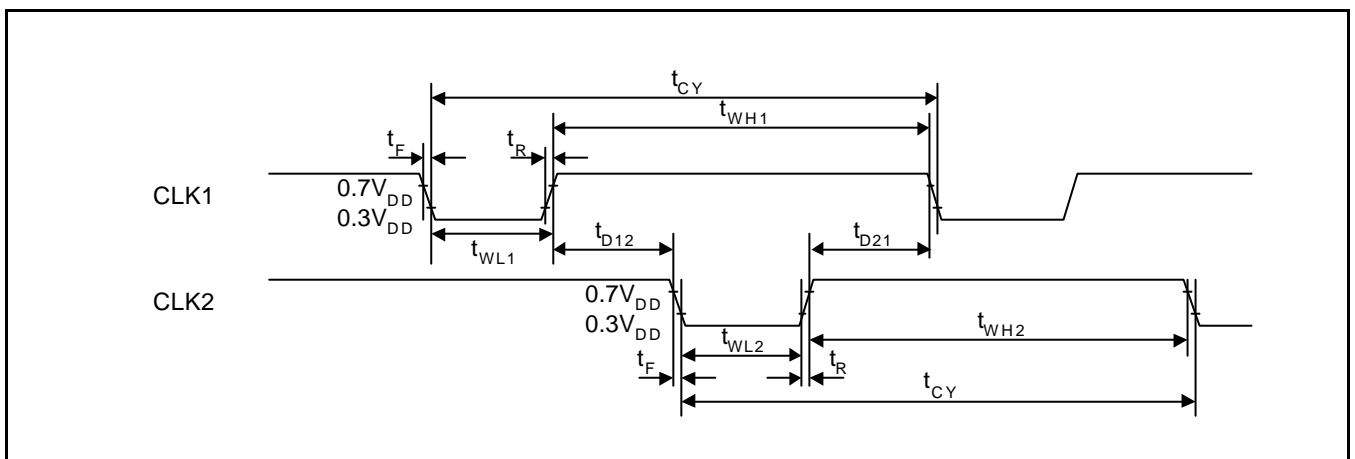

Figure 1. External Clock Waveform

## Display Control Timing

Characteristic	Symbol	Min	Typ	Max	Unit
FRM delay time	$t_{DF}$	-2	-	+2	us
M delay time	$t_{DM}$	-2	-	+2	us
CL "low" level width	$t_{WL}$	35	-	-	us
CL "high" level width	$t_{WH}$	35	-	-	us

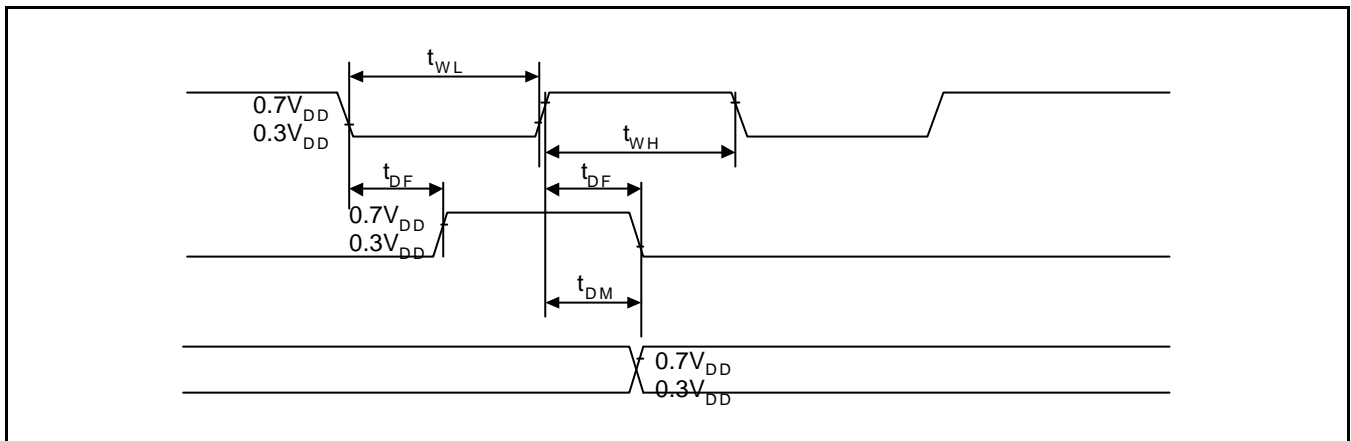

Figure 2. Display Control Waveform

MPU Interface

Characteristic	Symbol	Min	Typ	Max	Unit
E cycle	$t_C$	1000	–	–	ns
E high level width	$t_{WH}$	450	–	–	ns
E low level width	$t_{WL}$	450	–	–	ns
E rise time	$t_R$	–	–	25	ns
E fall time	$t_F$	–	–	25	ns
Address set-up time	$t_{ASU}$	140	–	–	ns
Address hold time	$t_{AH}$	10	–	–	ns
Data set-up time	$t_{DSU}$	200	–	–	ns
Data delay time	$t_D$	–	–	320	ns
Data hold time (write)	$t_{DHW}$	10	–	–	ns
Data hold time (read)	$t_{DHR}$	20	–	–	ns

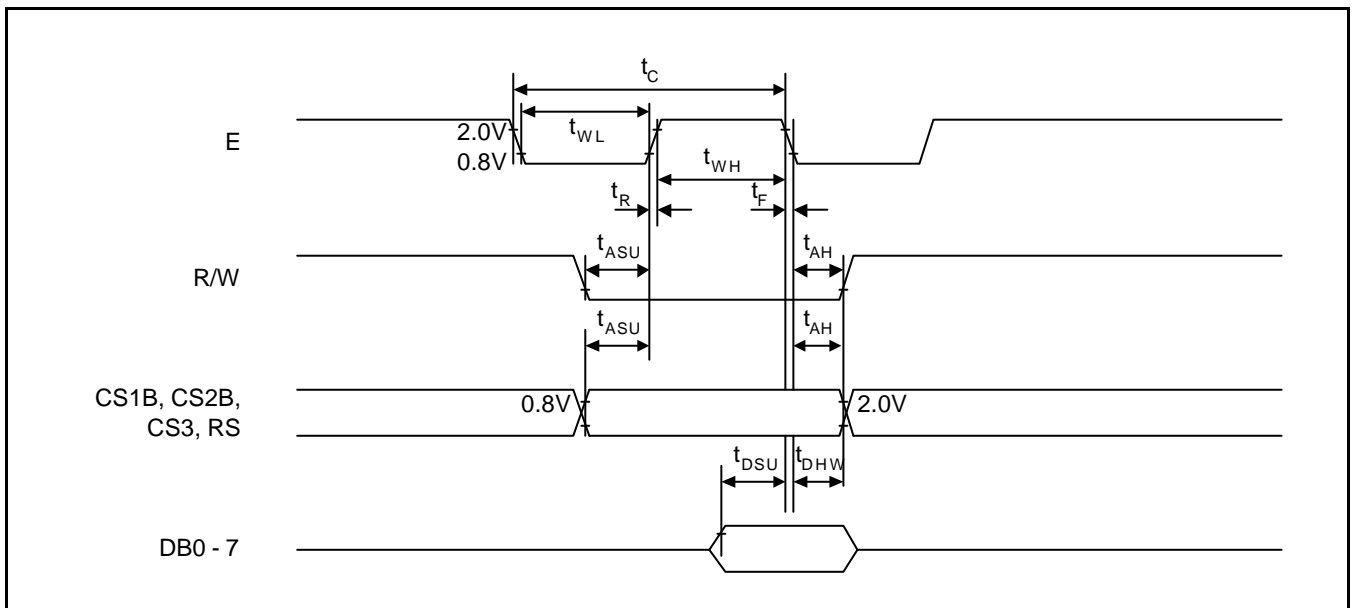

Figure 3. MPU Write Timing

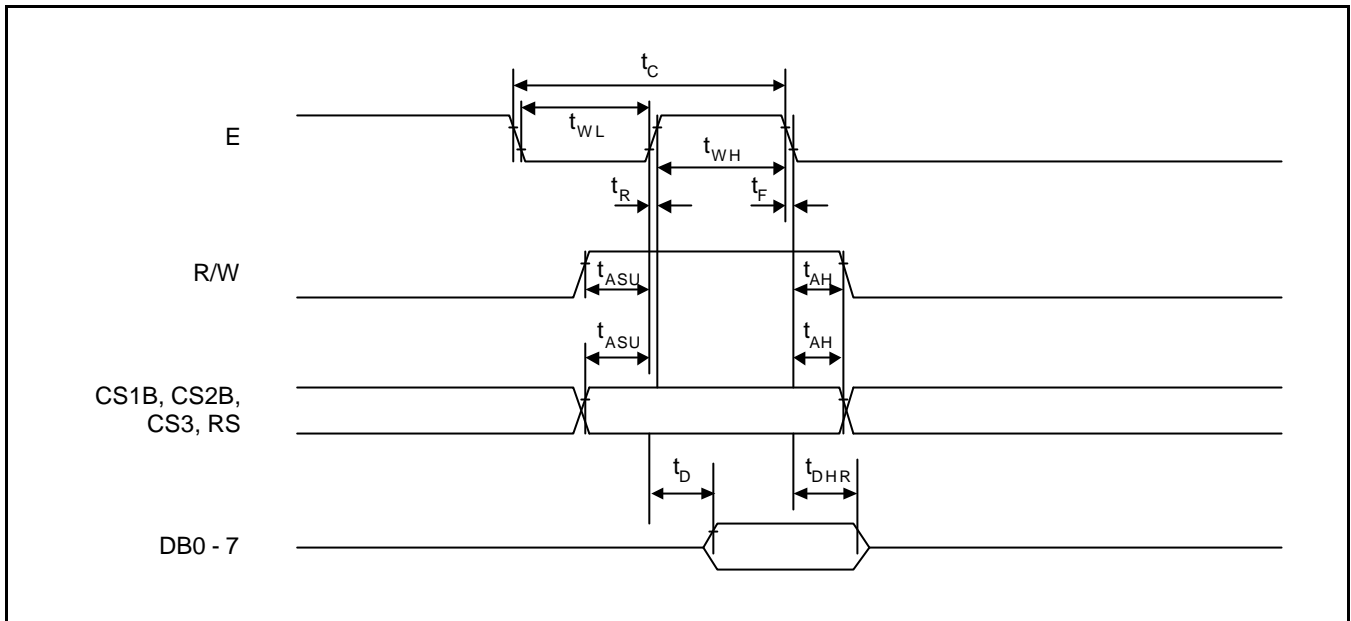

Figure 4. MPU Read Timing

## OPERATING PRINCIPLES AND METHODS

### I/O BUFFER

Input buffer controls the status between the enable and disable of chip. Unless the CS1B to CS3 is in active mode, Input or output of data and instruction does not execute. Therefore internal state is not change. But RSTB and ADC can operate regardless CS1B-CS3.

### INPUT REGISTER

Input register is provided to interface with MPU which is different operating frequency. Input register stores the data temporarily before writing it into display RAM. When CS1B to CS3 are in the active mode, R/W and RS select the input register. The data from MPU is written into input register. Then Writing it into display RAM. Data latched for falling of the E signal and write automatically into the display data RAM by internal operation.

### OUTPUT REGISTER

Output register stores the data temporarily from display data RAM when CS1B, CS2B and CS3 are in active mode and R/W and RS = H, stored data in display data RAM is latched in output register. When CS1B to CS3 is in active mode and R/W = H, RS = L, status data (busy check) can read out. To read the contents of display data RAM, twice access of read instruction is needed. In first access, data in display data RAM is latched into output register. In second access, MPU can read data which is latched. That is, to read the data in display data RAM, it needs dummy read. But status read is not needed dummy read.

RS	R/W	Function
L	L	Instruction
	H	Status read (busy check)
H	L	Data write (from input register to display data RAM)
	H	Data read (from display data RAM to output register)

## RESET

The system can be initialized by setting RSTB terminal at low level when turning power on, receiving instruction from MPU.

When RSTB becomes low, following procedure is occurred.

- Display off
- Display start line register become set by 0. (Z-address 0)

While RSTB is low, No instruction except status read can be accepted. Therefore, execute other instructions after making sure that DB4 = 0 (clear RSTB) and DB7 = 0 (ready) by status read instruction. The Conditions of power supply at initial power up are shown in Table 2.

**Table 2. Power Supply Initial Conditions**

Item	Symbol	Min	Typ	Max	Unit
Reset time	$t_{RS}$	1.0	—	—	us
Rise time	$t_R$	—	—	200	ns

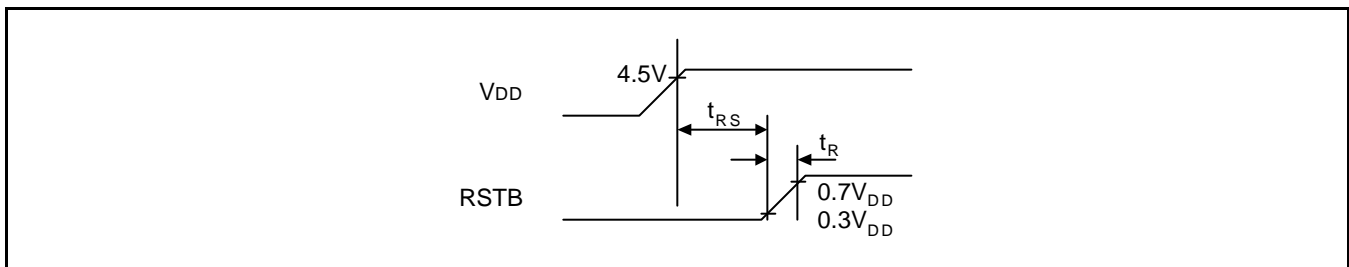

**Busy Flag**

Busy Flag indicates that S6B0108 is operating or no operating. When busy flag is high, S6B0108 is in internal operating. When busy flag is low, S6B0108 can accept the data or instruction. DB7 indicates busy flag of the S6B0108.

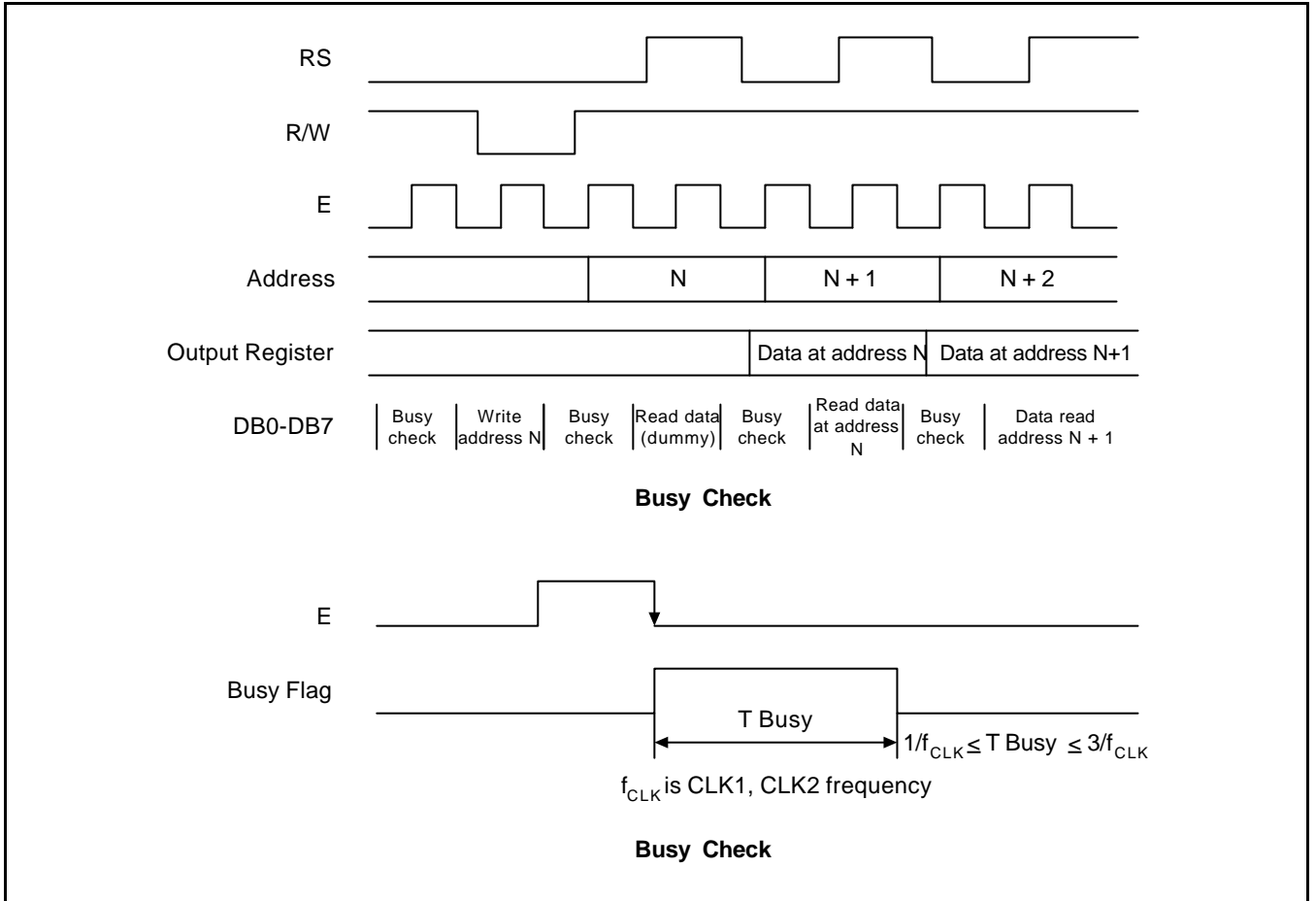

### Display ON/OFF Flip - Flop

The display on/off flip-flop makes on/off the liquid crystal display. When flip-flop is reset (logical low), selective voltage or non selective voltage appears on segment output terminals. When flip-flop is set (logic high), non selective voltage appears on segment output terminals regardless of display RAM data. The display on/off flip-flop can changes status by instruction. The display data at all segment disappear while RSTB is low. The status of the flip-flop is output to DB5 by status read instruction. The display on/off flip-flop synchronized by CL signal.

### X Page Register

X page register designates pages of the internal display data RAM. Count function is not available. An address is set by instruction.

### Y Address Counter

Y address counter designates address of the internal display data RAM. An address is set by instruction and is increased by 1 automatically by read or write operations of display data.

### Display Data RAM

Display data RAM stores a display data for liquid crystal display. To indicate on state dot matrix of liquid crystal display, write data 1. The other way, off state, writes 0.

Display data RAM address and segment output can be controlled by ADC signal.

- ADC = H → Y-address 0:S1 - Y address 63:S64
- ADC = L → Y-address 0:S64 - Y address 63:S1

ADC terminal connect the  $V_{DD}$  or  $V_{SS}$ .

### Display Start Line Register

The display start line register indicates of display data RAM to display top line of liquid crystal display. Bit data (DB<0:5>) of the display start line set instruction is latched in display start line register. Latched data is transferred to the Z address counter while FRM is high, presetting the Z address counter. It is used for scrolling of the liquid crystal display screen.

## DISPLAY CONTROL INSTRUCTION

The display control instructions control the internal state of the S6B0108. Instruction is received from MPU to S6B0108 for the display control. The following table shows various instructions.

Instruction	RS	R/W	DB7	DB6	DB5	DB4	DB3	DB2	DB1	DB0	Function	
Display on/off	L	L	L	L	H	H	H	H	H	L/H	Controls the display on or off. Internal status and display RAM data is not affected. L: OFF, H: ON	
Set address (Y address)	L	L	L	H	Y address (0 - 63)						Sets the Y address in the Y address counter.	
Set page (X address)	L	L	H	L	H	H	H	Page (0 - 7)			Sets the X address at the X address register.	
Display start line (Z address)	L	L	H	H	Display start line (0 - 63)						Indicates the display data RAM displayed at the top of the screen.	
Status read	L	H	Busy	L	On/Off	Reset	L	L	L	L	Read status. BUSY L: Ready H: In operation ON/OFF L: Display ON H: Display OFF RESET L: Normal H: Reset	
Write display data	H	L	Write data									Writes data (DB0:7) into display data RAM. After writing instruction, Y address is increased by 1 automatically.
Read display data	H	H	Read data									Reads data (DB0:7) from display data RAM to the data bus.

**DISPLAY ON/OFF**

RS	R/W	DB7	DB6	DB5	DB4	DB3	DB2	DB1	DB0
0	0	0	0	1	1	1	1	1	D

The display data appears when D is 1 and disappears when D is 0. Though the data is not on the screen with D = 0, it remains in the display data RAM. Therefore, you can make it appear by changing D = 0 into D = 1.

**SET ADDRESS (Y ADDRESS)**

S	R/W	DB7	DB6	DB5	DB4	DB3	DB2	DB1	DB0
0	0	0	1	AC5	AC4	AC3	AC2	AC1	AC0

Y address (AC0 - AC5) of the display data RAM is set in the Y address counter. An address is set by instruction and increased by 1 automatically by read or write operations of display data.

**SET PAGE (X ADDRESS)**

RS	R/W	DB7	DB6	DB5	DB4	DB3	DB2	DB1	DB0
0	0	1	0	1	1	1	AC2	AC1	AC0

X address(AC0 - AC2) of the display data RAM is set in the X address register. Writing or reading to or from MPU is executed in this specified page until the next page is set.

**DISPLAY START LINE (Z ADDRESS)**

RS	R/W	DB7	DB6	DB5	DB4	DB3	DB2	DB1	DB0
0	0	1	1	AC5	AC4	AC3	AC2	AC1	AC0

Z address (AC0 - AC5) of the display data RAM is set in the display start line register and displayed at the top of the screen. When the display duty cycle is 1/64 or others(1/32 - 1/64), the data of total line number of LCD screen, from the line specified by display start line instruction, is displayed.

**STATUS READ**

RS	R/W	DB7	DB6	DB5	DB4	DB3	DB2	DB1	DB0
0	1	BUSY	0	ON/OFF	RESET	0	0	0	0

- **BUSY**  
When BUSY is 1, the Chip is executing internal operation and no instructions are accepted.  
When BUSY is 0, the Chip is ready to accept any instructions.
- **ON/OFF**  
When ON/OFF is 1, the display is off.  
When ON/OFF is 0, the display is on.
- **RESET**  
When RESET is 1, the system is being initialized.  
In this condition, no instructions except status read can be accepted.  
When RESET is 0, initializing has finished and the system is in the usual operation condition.

**WRITE DISPLAY DATA**

RS	R/W	DB7	DB6	DB5	DB4	DB3	DB2	DB1	DB0
1	0	D7	D6	D5	D4	D3	D2	D1	D0

Writes data (D0 - D7) into the display data RAM. After writing instruction, Y address is increased by 1 automatically.

**READ DISPLAY DATA**

RS	R/W	DB7	DB6	DB5	DB4	DB3	DB2	DB1	DB0
1	1	D7	D6	D5	D4	D3	D2	D1	D0

Reads data (D0 - D7) from the display data RAM. After reading instruction, Y address is increased by 1 automatically.

APPLICATION CIRCUIT

1/64 DUTY COMMON DRIVER (S6B0107) INTERFACE CIRCUIT

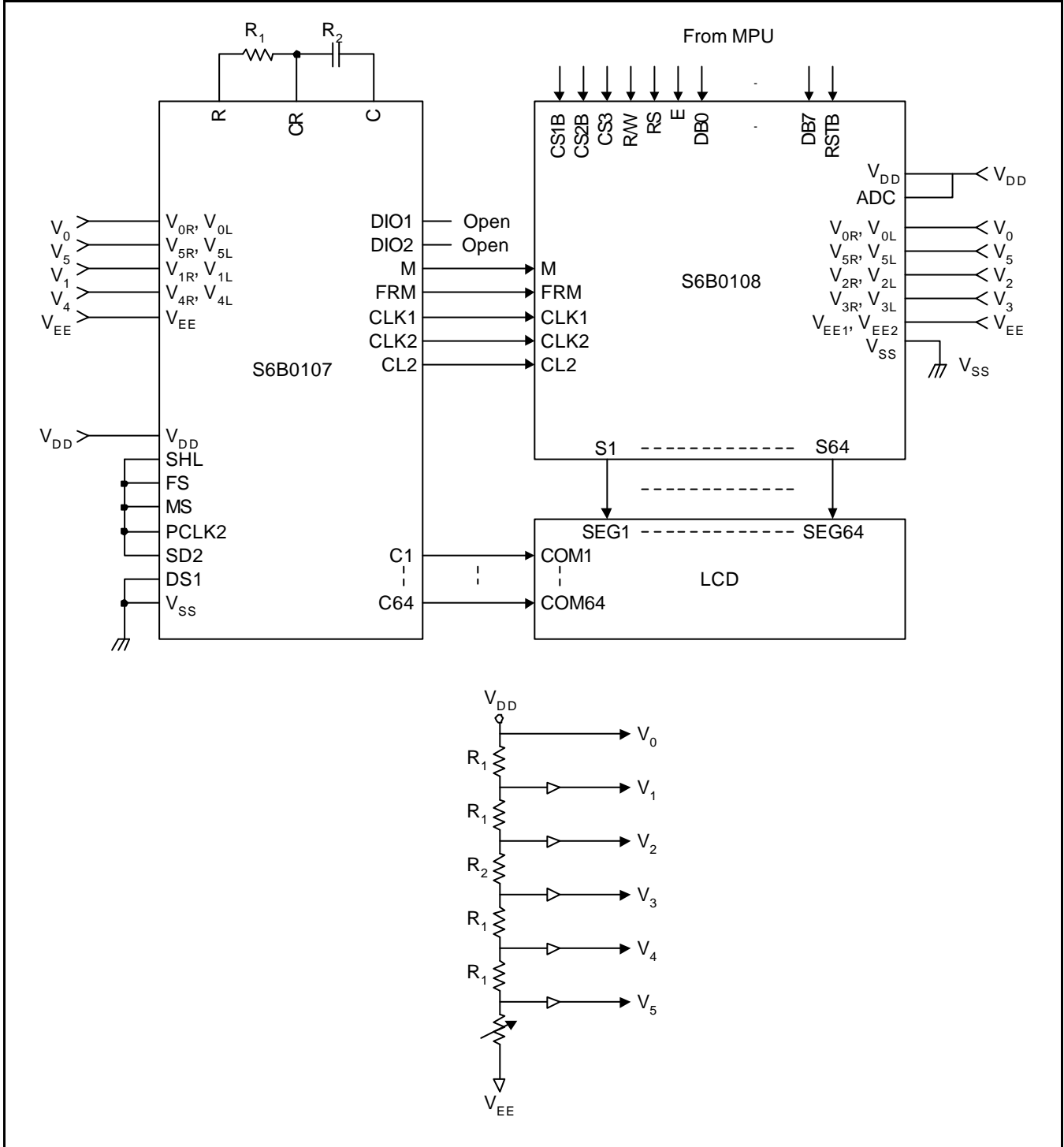

TIMING DIAGRAM (1/64 DUTY)

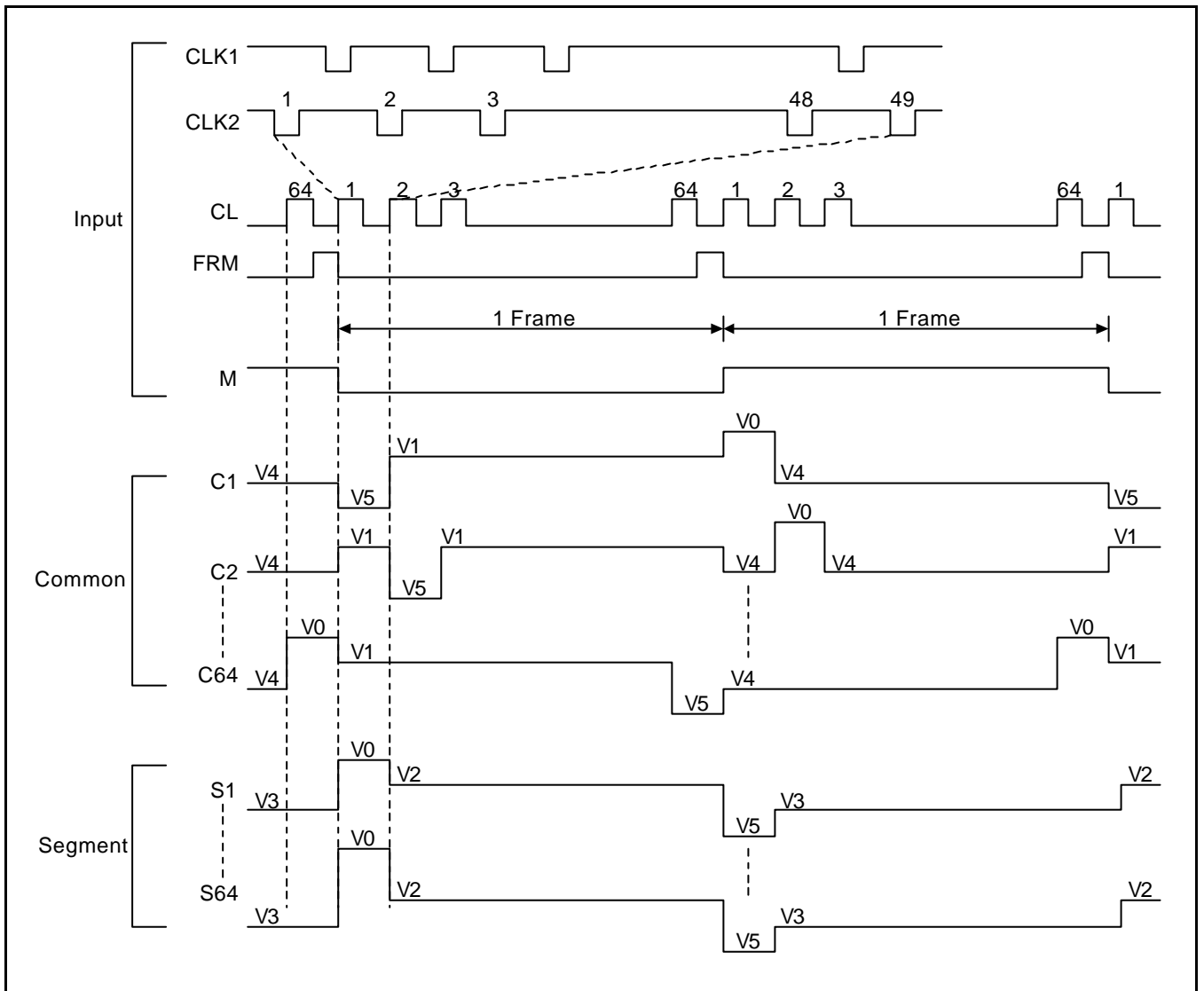

LCD PANEL INTERFACE APPLICATION CIRCUIT

